

USER INSTRUCTIONS

Lathe chuck guard SPS-400-L-M

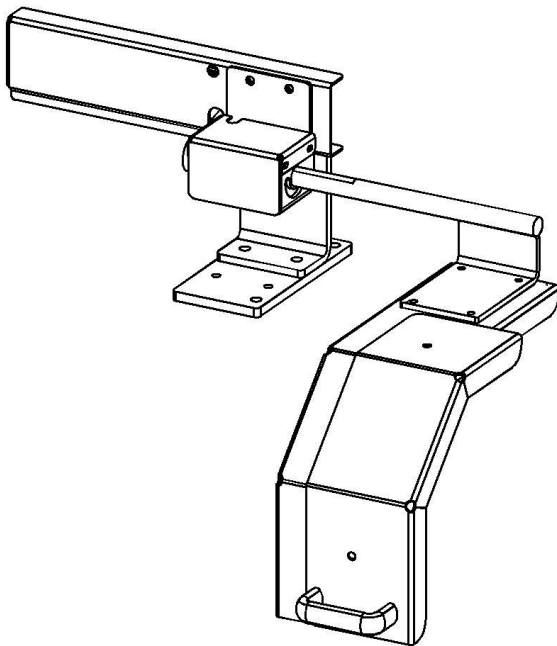

Uses

The protector is meant to be used as protection over the lathe chuck in manual lathes with chuck (jaws out) diameters between 250-400 mm.

Dimensions

The chuck protector width is adjustable between 130-175 mm. The dimensions of the fastening console are 100 x 200 mm. The protector has a total mass of approx. 12 kg.

Installation

The user can himself install the protector over the lathe's spindle box by using the fastening console. Fastening requires using 3-4 M8 or M10 screws for sufficient sturdiness to be achieved. The fastening console needs to be placed so that the protector plate is equal distance from all its sides from the chuck (when the chuck jaws are extended to their maximum, the distance to the chuck protector needs to be 30-50 mm).

The sufficiency of the fastening console's overall lateral space needs to be ensured. The connection instructions are provided with the micro switch.

If unclear on any aspect of this, please contact the manufacturer.

Operation

When in operation, the protector plate is pulled over from the side to cover the chuck.

When the chuck is at a standstill, the chuck protector can be moved by means of the handle to the left side so that it is over the spindle box. When this is done, the chuck's jaws can be tightened. It should be noted that the micro switch prevents the machine from starting up if the protector is not fully in its operational position.

Inspection and maintenance

The fastening console's rails need to be cleaned and oiled as necessary to ensure that the protector's lines of motion remain sufficient. If the protector has been dented, e.g. the fastening console is bent, the damaged parts must be replaced with new parts. The functioning of the micro switch needs to be tested regularly. (E.g. weekly).

The warranty period is two (2) years from the date of purchase.

Keuruun FinnSafety Oy

EC Declaration of conformity for machinery

(Machinery Directive 2006/42/EC, Annex II., sub. A)

EY-vaatimusten mukaisuusvakuutus koneesta

(Konedirektiivi 2006/42/EY, Liite II A)

EG-försäkran om maskinens överensstämmelse

(Maskindirektivet 2006/42/EG, bilaga 2, A)

Manufacturer / Valmistaja / Tillverkare: Keuruun FinnSafety Oy

Address / Osoite / Adress : PI 39, FI-42701 Keuruu

Name and address of the person authorised to compile the technical file:

Henkilön nimi ja osoite, joka on valtuutettu kokoamaan teknisen tiedoston:

Namn och adress till den person som är behörig att ställa samman den tekniska dokumentationen:

Name / Nimi / Namn: Mika Hetekorpi Address / osoite / Adress: Paljekuja 4 FI-42107 Keuruu

Herewith we declare that safety component

Vakuuttaa, että turvakomponentti

Försäkrar härmed att säkerhets komponent

FinnSafetySystem GUARD	SPS-400-	SN 0001400 – SN 0001999
FinnSafetySystem GUARD	SPS-400-	SN 0001400 – SN 0001999
FinnSafetySystem GUARD	SPS-400-	SN 0001400 – SN 0001999

- Is in conformity with the relevant provisions of the Machinery Directive (2006/42/EC)
- on konedirektiivin (2006/42/EY) asiaankuuluvien säännösten mukainen
- Har följande grundläggande krav i maskindirektivet (2006/42/EC) tillämpats och fullföljts

And are manufactured according standard: Guards SFS-EN ISO 14120

Ja on valmistettu standardin Guards SFS-EN ISO 14120mukaan

Vi försäkrar dessutom att standard Guards SFS-EN ISO 14120 har använts

Place,date / Paikka, aika / Ort och datum: Keuruu 01.01.2016

Signature / allekirjoitus / Signatur:



Mika Hetekorpi

Managing Director / toimitusjohtaja / VD

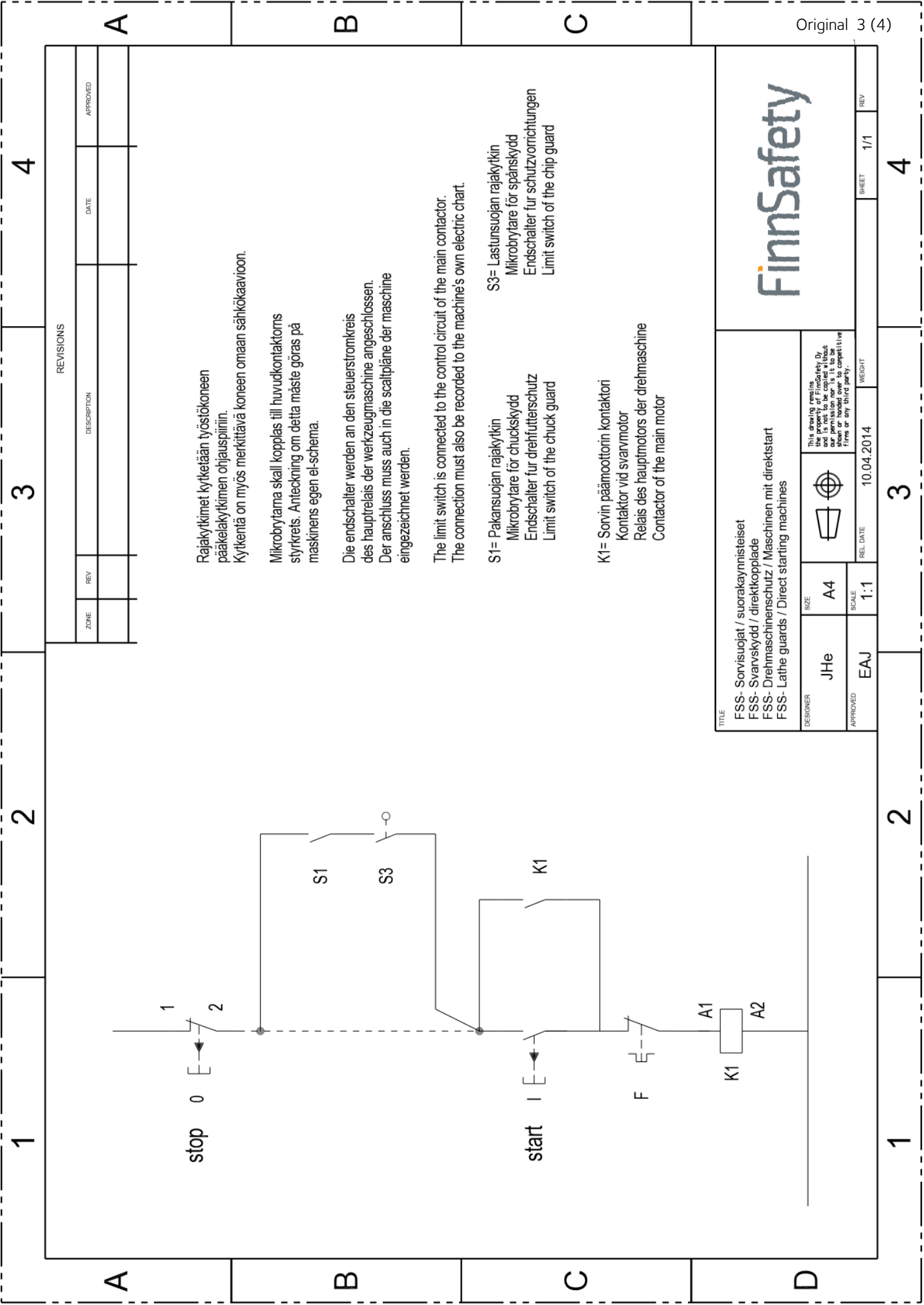

REVISIONS			
ZONE	REV	DESCRIPTION	DATE

APPROVED

Rajakytkimet kytketään työstökoneen pääkela kytkimen ohjauspiiriin. Kytkentä on myös merkittävä koneen omaan sähkökaavioon.

Mikrobrytarna skall kopplas till huvudkontaktorns styrkrets. Anteckning om detta måste göras på maskinens egen el-schema.

Die endschalter werden an den steuerstromkreis des hauptrelais der werkzeugmaschine angeschlossen. Der anschluss muss auch in die scaltpläne der maschine eingezeichnet werden.

The limit switch is connected to the control circuit of the main contactor. The connection must also be recorded to the machine's own electric chart.

S1= Pakansuojan rajakytkin
Mikrobrytare för chuckskydd
Endschalter für drehfutterschutz
Limit switch of the chuck guard

S3= Lastansuojan rajakytkin
Mikrobrytare för spånskydd
Endschalter für schutzvorrichtungen
Limit switch of the chip guard

K1= Sorvin päämoottorin kontaktori
Kontaktör vid svarmotor
Relais des hautmotors der drehmaschine
Contactor of the main motor

TITLE FSS- Sorvisuojat / suorakynnisteiset FSS- Svarskydd / direktkopplade FSS- Drehmaschinenschutz / Maschinen mit direktstart FSS- Lathe guards / Direct starting machines			
DESIGNER JHe	SIZE A4		This drawing contains information that is confidential to FinnSafety Oy and is not to be copied without our permission nor is it to be used for any competitive firms or any third party.
APPROVED EAJ	SCALE 1:1	REL. DATE 10.04.2014	WEIGHT SHEET 1/1

4

3

2

1

A

B

C

D

3

2

1

4

4

3

2

1

A

B

C

REVISIONS			
ZONE	REV	DESCRIPTION	DATE

Rajakytkimet kytketään työskoneen pääkelauskytkimen ohjauksiin.
Kytkentä on myös merkittävä koneen omaan sähkökaaviioon.

Mikrobrytarna skall kopplas till huvudkontaktorns styckrets. Anteckning om detta måste göras på maskinens egen el-schema.

Die endschalter werden an den steuerstromkreis des hauptrelais der werkzeugmaschine angeschlossen. Der anschluss muss auch in die scaltpläne der maschine eingezeichnet werden.

The limit switch is connected to the control circuit of the main contactor.
The connection must also be recorded to the machine's own electric chart.

S1= Pakansuojan rajakytkin
Mikrobrytare för chuckskydd
Endschalter für drehtfterschutz
Limit switch of the chuck guard

S2= Käyttövivun rajakytkin
Mikrobrytare vid kopplingsaxel
Endschalter des betätigungshebels
Limit switch of the operation lever

K1= Sorvin päämoottorin kontaktori
Kontaktör vid svarvmotor
Relais des hautmotors der drehmaschine
Contactor of the main motor

S3= Lastansuojan rajakytkin
Mikrobrytare för spånskydd
Endschalter für schutzvorrichtungen
Limit switch of the chip guard

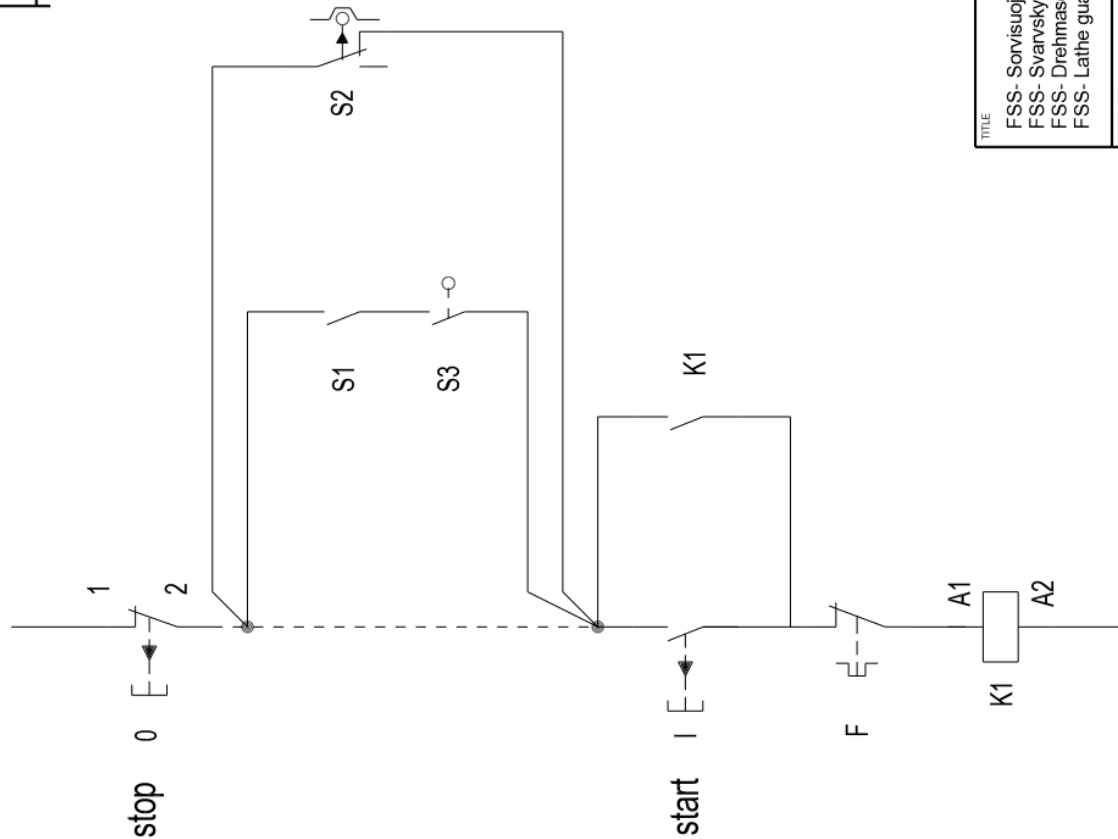

TITLE

FSS- Sorvisuojat / Lamellikytetyt koneet
FSS- Svarskydd / Lamellikplade maskiner
FSS- Drehmaschinen / Maschinen im dauerbetrieb
FSS- Lathe guards / Continuous starting machines

DESIGNER

JHe

SIZE

A4

REL. DATE

10.04.2014

This drawing remains the property of Finnsafety. It is not to be reproduced or used without our permission nor is it to be shown or handed over to competitive firms or any third party.

WEIGHT

SHEET

1/1

REV

4

4

3

2

1

A

B

C

D